

**Extensive inventory
of high quality
products from a
vendor you can trust**

Buffer Seals

Machined Plastics

Engineered Elastomers

Custom Molded Plastics

Kits

O-rings

Perfluoroelastomer Parts

Piston Cups, Rings & Seals

Pneumatic Seals

Rod Seals / U-Cups

Rotary Shaft Seals

T & Capped T-Seals

Wear Rings

Wipers



Headquarters
5250 West 73rd Street
Edina, MN 55439
Tel: (952) 835-1700
Fax: (952) 835-1701

sales@rtdygart.com
www.rtdygart.com

Chicago Office
7540 Linder Avenue
Skokie, IL 60077
Tel: (847) 675-1444
Fax: (847) 675-8889

(866) RTD-8883
(866-783-8883)

Shanghai Office
Suite C, 4F, Building One,
29 Jiatai Rd. Waigaoqiao
Free Trade Zone,
Shanghai

Tel: (86) 21-5866-5551
Fax: (86) 21-5866-5552



**CHEM-RING TEFLON®
ENCAPSULATED O-RINGS**



CHEM-RING FEATURES AND BENEFITS

Best of 2 Worlds combining the FEP (Teflon®) outer with a Resilient Inner Core! An encapsulated O-ring is a 2 component seal where the elastomer core imparts the memory and the FEP sleeve provides the chemical protection.

Viton® and Teflon® are registered trademarks of E.I. du Pont de Nemours and Company.

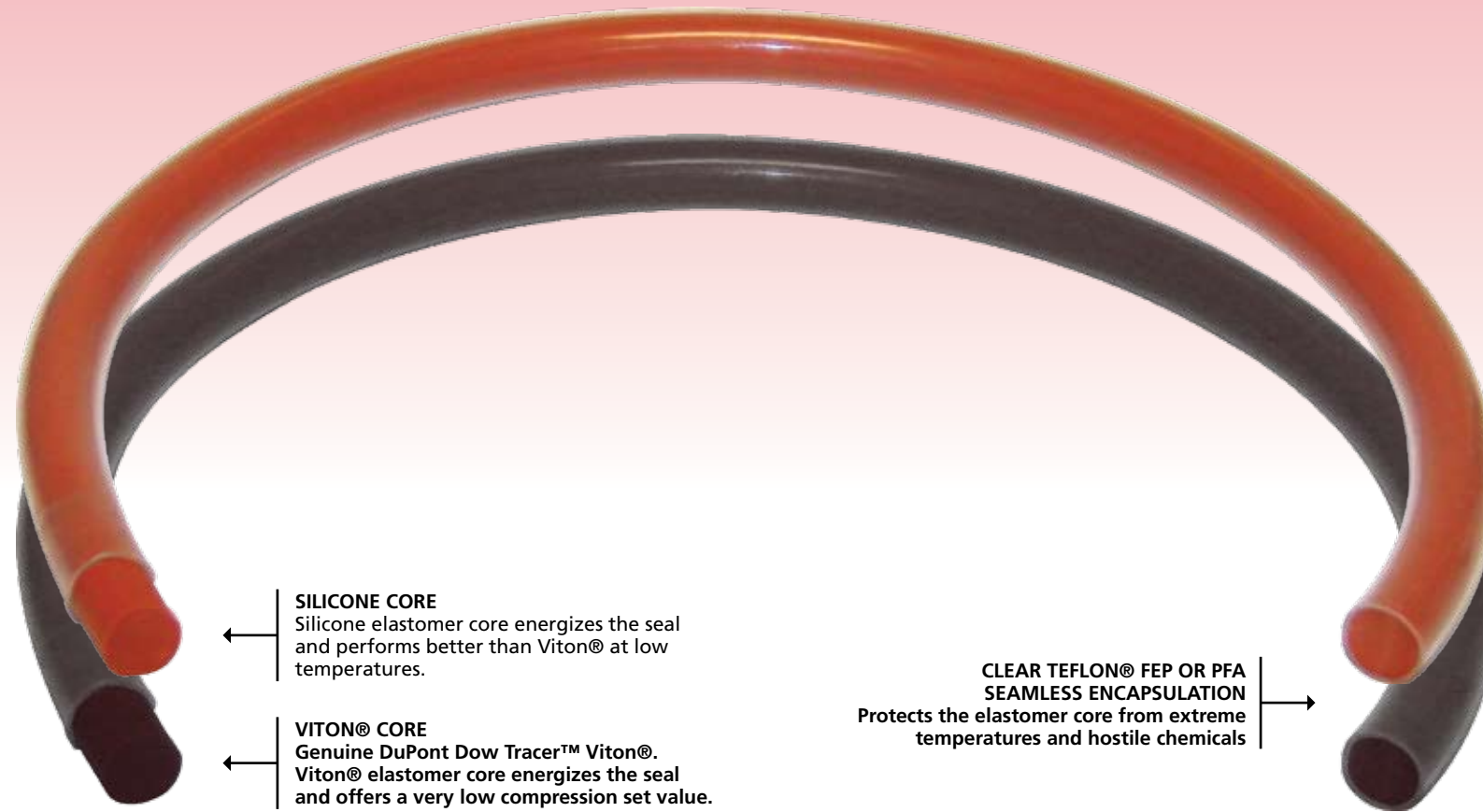

SILICONE CORE
Silicone elastomer core energizes the seal and performs better than Viton® at low temperatures.

VITON® CORE
Genuine DuPont Dow Tracer™ Viton®. Viton® elastomer core energizes the seal and offers a very low compression set value.

CLEAR TEFLON® FEP OR PFA SEAMLESS ENCAPSULATION
Protects the elastomer core from extreme temperatures and hostile chemicals

BROAD SIZE RANGE:

Available in standard and metric sizes from .059" cross section x ½" I.D. to virtually unlimited larger sizes.

OUTPERFORMS SOLID PTFE O-RINGS:

Chem-Ring encapsulated O-rings match the chemical and temperature resistance of solid PTFE O-rings, Chem-Ring™ encapsulated O-rings possess properties of elasticity and recovery which are crucial in many sealing applications.

ECONOMICAL:

Chem-Ring encapsulated O-rings economically, and may effectively, replace exotic compounds wherever corrosive fluids and gases cause premature seal failure.

NON-STICK SURFACE:

Provides easy cleanup of viscous materials.

SANITARY:

Eliminates contamination of fluids by elastomers. Sterilizable and autoclavable.

OUTSTANDING CHEMICAL RESISTANCE:

Chemical attack and swelling are primary causes of O-ring failure. Chem-Ring encapsulated O-rings are virtually chemically inert.

MINIMUM COMPRESSION SET:

Core materials (Silicone or Viton®) provide optimum resilience vs. compatibility.

SPECIFICATIONS

- ENCAPSULATION MATERIAL:** DuPont Teflon® FEP: Tetrafluoroethylene-Hexafluoropropylene. Dupont Teflon® PFA: Tetrafluoroethylene-Perfluoro (Propyl Vinyl Ether).
- CORE MATERIAL:** Silicone Grade ZZR 765B, DuPont Viton® Grade E-60C elastomers.
- CONTINUOUS SERVICE TEMPERATURE:**
 - Teflon® FEP Encapsulation with Silicone Core: -75F/-60C to 400F/204C.
 - Teflon® PFA Encapsulation with Silicone Core: -75F/-60C to 500F/260C
 - Teflon® FEP Encapsulation with HT Viton® Core: -10F/-23C to 400F/204C
 - Teflon® PFA Encapsulation with HT Viton® Core: -10F/-23C to 400F/204C
- COEFFICIENT OF FRICTION:** .1 to .2 on metal surfaces.
- WATER ABSORPTION:** <0.01.
- AVERAGE TOTAL SHORE A HARDNESS:** 85-90 shore A for solid silicone core. 90-95 shore A for solid Viton® core. 75-80 shore A for hollow silicone core.

GROOVE CONSTRUCTION RECOMMENDATIONS

CROSS SECTION	NOMINAL SQUEEZE	MIN. ID RANGE	MAX ID RANGE	GROOVE WIDTH
.070	.020	.250	1.50	.100
.103	.025	.500	2.50	.130
.139	.030	1.00	5.00	.175
.210	.045	2.10	ANY	.275
.275	.050	3.00	ANY	.350

NOTE: The above applies to minimum width and depth recommendations for machined grooves in metal. Recommended surface finish of 32 micro-inches for the bore and 16 micro-inches for the shaft.

KAMLOCK SEAL

RT/Dygart Encapsulated Gasket for KAMLOCK Couplings

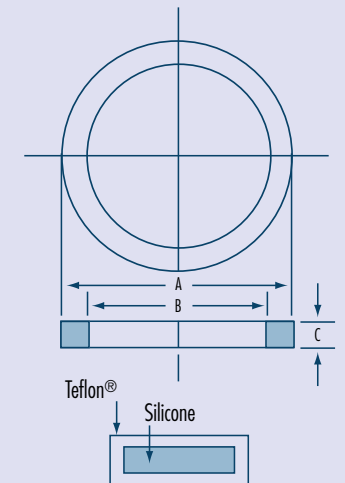

UNIVERSAL GASKET: Excellent chemical resistance and wide temperature range.

LEAK FREE SERVICE: Low compression set and elastomer core eliminates cold flow leakage found in solid PTFE O-Rings.

NON-STICK SURFACE: Low coefficient of friction allows easy installation and removal.

RT/Dygart Encapsulated Gaskets for KAMLOCK® Couplings are designed as universal, non-contaminating hose coupling seals. They eliminate the need to specify different elastomers for differing applications and eliminate coupling leakage through seal gasket failure due to chemical attack or creep of solid Teflon® gasket seals. RT/Dygart KAMLOCK® seals provide a superior seal for any bulk liquid transfer in manufacturing, distribution or storage.

RECTANGULAR FEP/SILICONE GASKETS FOR KAMLOCK® COUPLINGS

Coupling Nominal Size		Dimensions					
		Inches			mm		
Inches	mm	A	B	C	A	B	C
.500	12.70	1.024	.669	.157	26.0	17.0	4.00
.750	19.00	1.375	.875	.218	35.0	22.2	5.54
1.000	25.40	1.563	1.063	.250	39.5	27.0	6.35
1.250	31.70	1.938	1.359	.250	49.2	34.5	6.35
1.500	38.00	2.188	1.625	.250	55.6	41.3	6.35
2.000	50.80	2.625	2.000	.250	66.7	50.8	6.35
2.500	63.50	3.125	2.375	.250	79.4	60.3	6.35
3.000	76.30	3.719	3.000	.250	94.5	76.2	6.35
4.000	101.60	4.875	4.000	.250	123.6	101.6	6.35
6.000	152.40	7.063	6.000	.250	179.4	152.4	6.35